

## 1. Introduction

The **A-129 /x series of modules is a modular vocoder. The crucial components are the A-129 /1** (analysis section) and **A-129 /2** (synthesis section).

Module **A-129 /3** adds a **Slew Limiter** to the vocoder. It includes 5-way **Attenuators**, 5-way **Offset Generators**, and a **Slew Limiter** (which works on all the voltages at the five CV inputs simultaneously).

Using the **A-129 /3 just on its own**, two functions are available:

- **Attenuator:** whatever signal is patched into the CV input can be attenuated by your chosen amount before being sent to the CV output. The attenuation is set with a control knob.
- **Offset Generator:** whatever signal is patched into the CV input will have an offset voltage added to it before being sent to the output. The offset is variable with a control knob.

To use the Slew Limiter section of the 129 /3, you need to have module **A-129 /4 (Slew Limiter Controller)** as

well. It has several dedicated functions, and gives you control over the following slew limiter functions:

- Manual control of the slew rate
- CV control of the slew rate, with an input attenuator
- Choice of three functions: "Follow", "Slew" and "Freeze"
- "Freezing" the output voltages for the duration of a gate

H This set of functions is operated by the Slew Limiter Controller, A-129 /4.

Usually, the slew limiter is patched between the CV outputs of the analysis section and the CV inputs of the synthesis section (see chapter 5, User examples).

You can also use module A-129 /3, particularly in combination with A-129 /4, for other purposes. For example, using the A-129 /2 synthesis section, you can make a filterbank.

2. A-129 /3, /4 - Overview

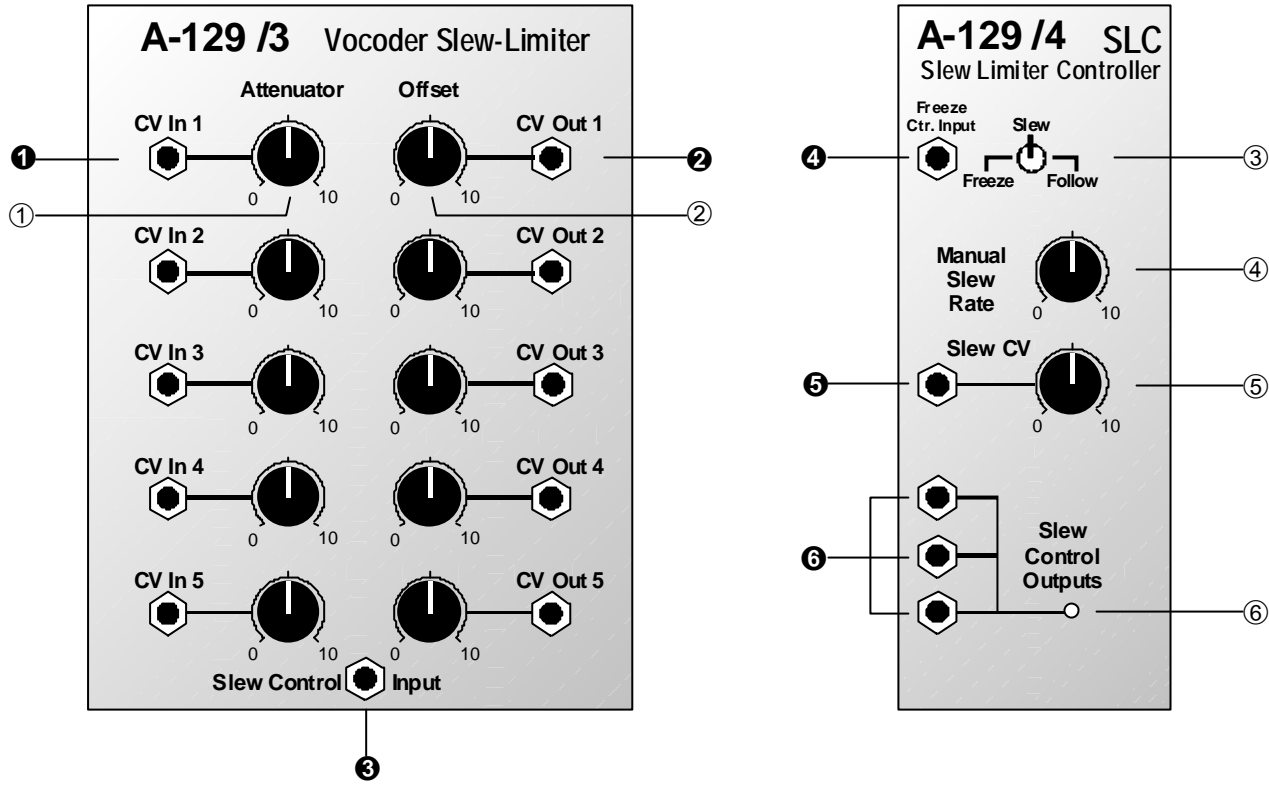

**A-129 /3****In- / Outputs:**

- ! CV In 1 ... CV In 5 : CV inputs
- " CV Out 1 ... CV Out 5 : CV outputs
- § Slew Control Input : Slew rate CV input; to access the slew limiting capabilities, patch the A-129 /4 output & into it.

**Controls:**

- 1 **Attenuator** : Attenuator for the CV input
- 2 **Offset** : Offset control for the CV output

**A-129 /4****In- / Outputs:**

- \$ Freeze Control Input : Gate input for controlling the freeze function
- % **Slew CV** : Slew rate control voltage input
- & Slew Control Outputs: 3 internally linked CV outputs to control slew rate

**Controls and indicators:**

- 3 **Switch** : Selector switch (3-position) to choose "Freeze", "Slew", or "Follow"
- 4 **Manual Slew Rate** : Knob for manual control of the slew rate
- 5 **Slew CV** : Attenuator for output %
- 6 **LED** : Indicator showing slew rate

### 3. Controls and indicators

#### 1 Attenuator

Use **Attenuator 1** to lower the signal at the corresponding output !. At a setting of 0, the input signal is completely switched off. At a setting of 10, the signal amplitude is completely unattenuated.

#### 2 Offset

Control 2 sets the **offset** which you want to add to the input signal. The offset control range goes from 0 V to +5 V.

#### 3 Switch

Switch 3 lets you **select the mode** in which the slew limiter works (see Fig. 1):

- **Freeze** : The instant you switch to this position, the signal at the output is **'frozen'** - a process similar to what happens with the A-148 Sample & Hold.
- **Slew** : The instant you switch to this position, the **slew limiter function** is selected.

- **Follow** : The instant you switch to this position the output signal **follows** the input signal.

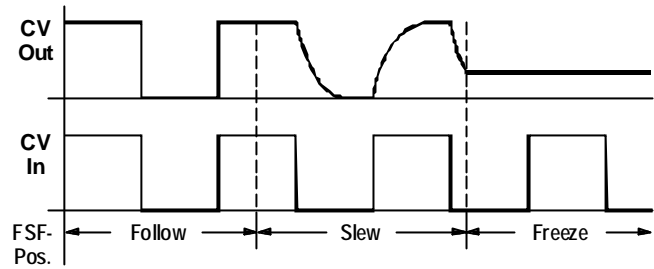
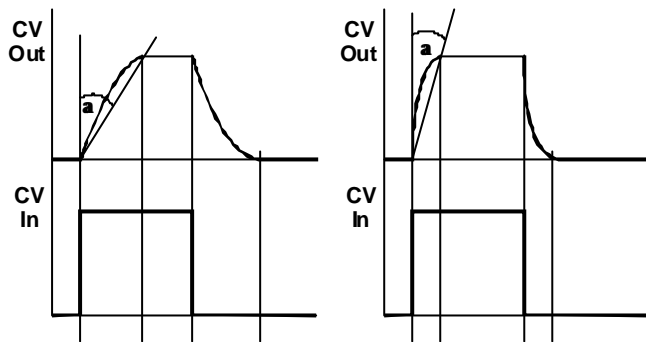

**Fig. 1:** The three slew limiter functions (Attenuator = 10, Offset = 0)

H In the "Slew" position, you can still freeze the signal by sending a gate pulse to input \$ (see \$ Freeze Control Input).

#### 4 Manual Slew Rate

This control sets the slew rate of the slew limiter - the steepness of the falling and rising edges of the waveform (see Fig. 2).



**Fig. 2:** Slew rate explanatory diagram  
(Attenuator=10, Offset=0)

With the control set at 0, the output signal is identical to the input.

H The precise **slew rate** is decided by a combination of the position of control 4, the control voltage available at input %, and the position of attenuator 5.

## 5 Slew CV

The **amplitude** of the control voltage at input % is controlled with this attenuator 5.

## 6 LED

The LED indicates the mode of the slew limiter signal at output &:

- dim : **freeze**
- bright : **follow**

## 4. In- / Outputs

### ! CV In 1 ... CV In 5

Sockets ! are **CV inputs**. This is where you patch in the voltages you would like to modify - ie, attenuate, offset, or smooth out by slew limiting.

### " CV Out 1 ... CV Out 5

Sockets " are **CV outputs**, at which the modified signals are available.

Each output signal is affected by a **combination of the attenuator, offset and slew limiter functions**.

### § Slew Control Input

Socket § is the **input** for the CV generated by the A-129 /4 **Slew Limiter Controller**.

This input should be connected with output & on the A-129 /4.

**This is a specialised control signal which must come from the A-129 /4.** Connecting signals from other modules won't make sense.

### \$ Freeze Control Input

A gate signal at **input \$** freezes the slew limiter's output signal (see Fig. 3).

H This function is only active when the switch 3 is in the 'slew' position.

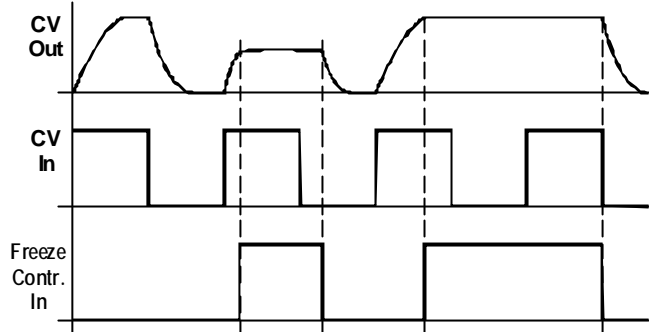

**Fig. 3:** Using a gate signal to freeze a voltage

## % Slew CV

**Input** % is where the CV should be patched in to control the slew rate. The amplitude of the CV can be set with the attenuator 5 if required.

## & Slew Control Outputs

Sockets & are the slew limiter controller's outputs. They're internally connected (a sort of mini-multiple), and are designed to provide the control voltage to the **A-129 /3**.

Connect one of the outputs to an A-129 /3 control input.

## 5. User examples

### Basic layout

Fig. 4 shows the standard layout for using the A-129 /3 and A-129 /4. The A-129 /3 is inserted into the control voltage chain, sandwiched between the analysis and synthesis sections.

For total control of a 15-band vocoder, you need three A-129 /3 modules. It's quite possible to control the slew limiter function of these three with one Slew Limiter Controller A-129 /4. There's also the option, though, of using up to three, to treat different bands of the vocoder in different ways.

The standard layout in Fig. 4 provides the following control functions:

- CV to control the level of one or more vocoder channels or bands (using the attenuator),
- Smoothing the transition between vowels (slew limiter function),
- Vowel hold (freeze),
- Transposing vocoder channels (offset).



Abb. 4: Basic set-up for the A-129 /3 and A-129 /4

### Further adventures in vocoder control

Using the layout in Fig. 4 (and also not forgetting the tips and suggestions for experimentation in the A-129 /1 and A-129 /2 manuals), you should be able to produce all the most widely-used vocoder effects. By patching in other modules, though, you should be able to go 'one step beyond'.

For a start, the voltages for the synthesis section don't have to come from the analysis section. Possible choices for modulation sources from which to control certain channels within the vocoder might include:

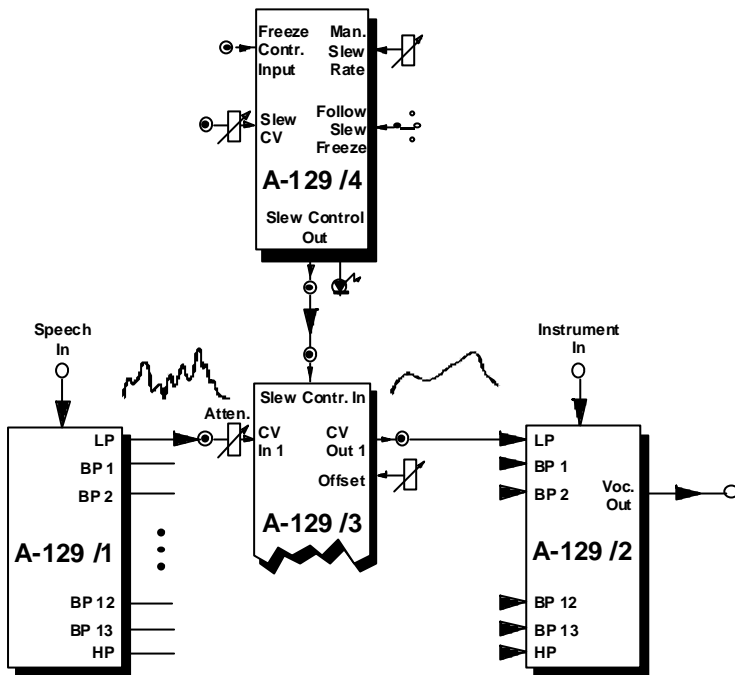
- ADSRs (A-140, A-141) for envelope control of timbres
- LFO's (A-145, A-146, A-147) for strange repeated vocal timbres
- Sample-and-hold (A-118) for random vowel sounds
- Shepard-Generator (A-191) for continuous filter effects
- Using an A-191 to control various vocoder channels via MIDI - for instance aftertouch or velocity.



- P Because as a modular vocoder the A-129 is totally open-ended, it would be wrong to be prescriptive about its use. Better to appeal to your sense of adventure and experimentation. Particularly when you add other modules into the equation, the A-129 should enable you to create some extraordinary sounds.
- P Especially to begin with, though, don't forget the sound source and signal processing tips and suggestions in the basic vocoder modules' manuals.

### A-129 /2 as a filter bank

The vocoder's synthesis section can be used in conjunction with the A-129 /3 as a **filter bank** (see Fig. 5).

The A-129 /3's offset controls govern the intensity of the individual frequency bands within the total audio spectrum (the output of the synthesis section).

You can also create a sort of voltage controlled filter bank by using CVs from a wide range of modules to set or modulate the levels of the frequency bands. See user examples in the basic modules' manuals, and 'Further adventures' in this manual.

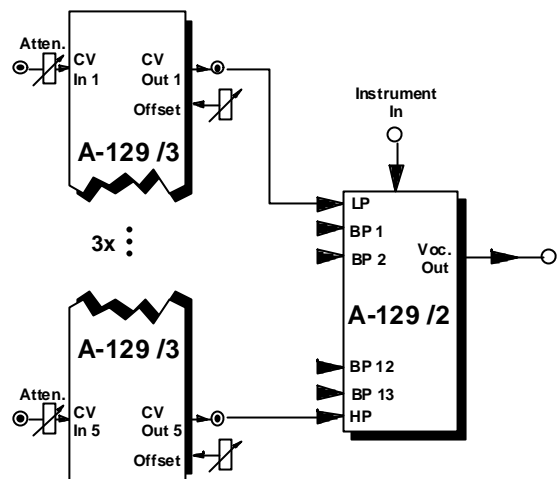

**Fig. 5:** A-129 /2 and A-129 /3s as a filter bank

## 6. Patch-Sheet

The following diagrams of the module can help you recall your own **Patches**. They're designed so that a complete 19" rack of modules will fit onto an A4 sheet of paper.

Photocopy this page, and cut out the pictures of this and your other modules. You can then stick them onto another piece of paper, and create a diagram of your own system.

Make multiple copies of your composite diagram, and use them for remembering good patches and set-ups.

- P
- Draw in patchleads with colored pens.
  - Draw or write control settings in the little white circles.

